

Prism Projection, Inc.

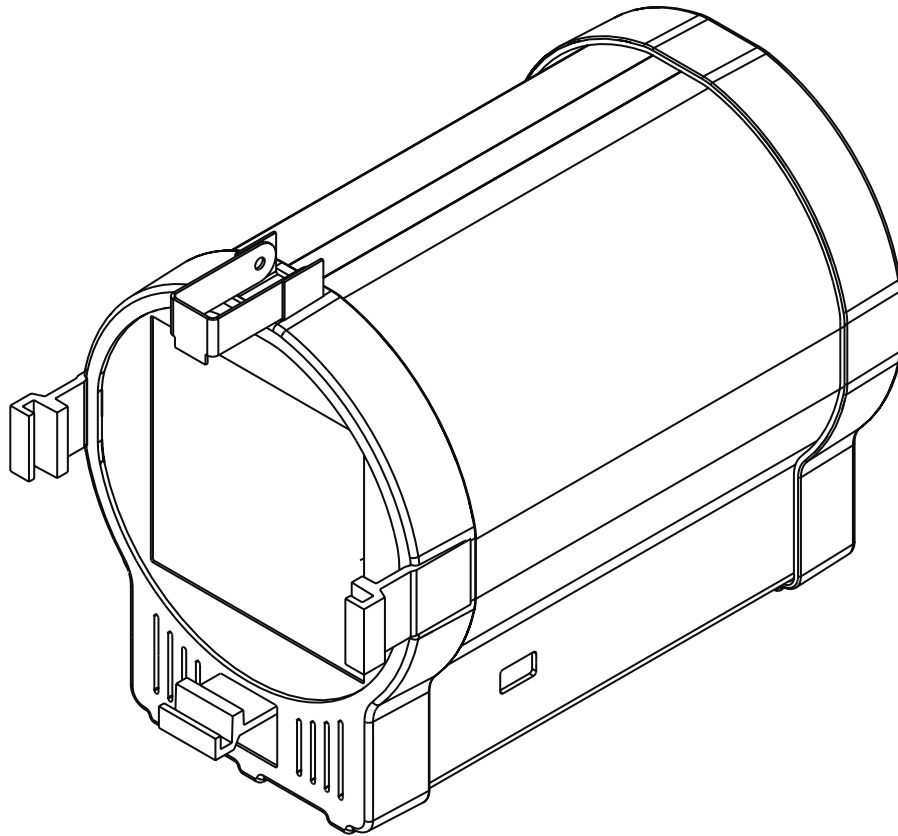

See what you've been missing™

RevEAL Studio with TrueSource® Operating Manual



www.prismprojection.com

Prism Projection Inc. - RevEAL Studio Operating Manual

Copyright © 2010. Prism Projection Inc. All Rights Reserved

Product Specifications and Information Subject to Change

The Product(s) and technologies described herein are protected by multiple issued and pending patents.

“RevEAL” and “RevEAL - Revolutionary Entertainment and Architectural Lighting™” are trademarks of Prism Projection Inc.

TrueSource® and “Prism Projection - See what you’ve been missing.®” are registered trademarks of Prism Projection Inc.

Product, Service or Company names mentioned herein may be trade or service marks of their respective owners.

Prepared January 2011, Updated February 2011

**Prism Projection, Inc.
8228 East 124th St. South
PO Box 448
Sully, IA 50251-0448
p: 641.594.3356**

Table of Contents

Warnings & Product Specifications	3
TrueSource® Technology	4
Live Color Metering	
Full Spectrum	
Interfacing with Color	
Optics	
TrueSource at a Glance	
Basic Installation	6
Mounting the product	
Attaching Data and Power Cables	
Accessory Holder and Optional Hardware	8
Top Hat	
Egg Crate	
Wide Lenses	
Interface Panel	9
Menu Tree	
Fixture Address	11
Modes and DMX Channels	12
Color Modes	
White (CCT)	
Intensity	
Advanced Settings	16
Energy	
Beam Angle	
Algorithm	
Reset to Factory Defaults	
Channel Map	
Standalone Control	19
TrueSource Screen	20

Warnings & Product Specifications

Read This Manual Prior To Use

- This product is NOT for residential use.
- This product is intended for use by qualified individuals in the field of entertainment lighting.
- This product is designed for damp conditions, but is NOT to be used in wet locations.
- Due to risk of injury the safety cable MUST be attached while the product is suspended.
- The product MUST be attached to the appropriate power, which meets the following conditions:
 - 90-264 VAC
 - 47-63 Hz
 - NOT for use on dimming circuits.
- Any attempt to disassemble or service the product other than described in this user manual will void the warranty and may result in injury.

TrueSource® Technology

After significant research and development efforts, Prism Projection has solved many of the problems associated with LED based lighting devices developing the TrueSource® system. TrueSource assures color consistency by utilizing active live color metering, achieves a full spectral response by using carefully selected multiple primary emitters and provides a consistent flat field with next generation optics and reflector systems.

Live Color Metering

At the heart of every TrueSource system is a Tristimulus color sensor. Tristimulus sensors, while electronic, actually “see” in a way that mimics the human eye’s response to color. Even though every human sees color differently, there are well established base lines for normal color response. By taking live measurements and adjusting how each LED or group of LEDs is being driven, the problems of color shift during use are removed. Tristimulus values are referenced to the well established CIE 1931 2° observer color space. By referencing a standard, TrueSource systems are inherently calibrated to each other. The problems of using only an initial calibration and predictive algorithms are not an issue with TrueSource systems.

Full Spectrum

TrueSource systems use several colors of primary emitters. At the minimum each TrueSource system will use 5 primary colors. These primaries are carefully chosen to minimize the valleys of the SED curve. When outputting 3200k “white”, TrueSource systems have a CRI of 95+. With deep understanding of how to drive each individual LED, TrueSource is not locked into only using a fixed number of primary emitters. TrueSource is also flexible enough to utilize LEDs from several manufacturers at once. With this discreet control, TrueSource systems can pick from the best available LEDs on the market.

Since all TrueSource enabled instruments are structured to provide a full spectral response, they have a very wide gamut.

Interfacing with Color

TrueSource systems allow the designers and operators to ask for and interface with color in very specific ways not normally seen in current lighting equipment. Instead of asking designers to describe color in a non-standardized way, ie. unknown RGB values, RGBW, RGBA, RGBCA, or seven discreet primaries. TrueSource

Prism Projection Inc. - RevEAL Studio Operating Manual

instruments can be configured to respond directly to x,y coordinates on the CIE 1931 2° color space. An RGB mode that is based on the NTSC gamut, but slightly wider is available. The designer may also elect to use Hue and Saturation to describe the desired color. Each of these modes uses a dedicated dimmer channel that does not shift the color. Designers may also add a specific Correlated Color Temperature channel (CCT). The CCT channel takes over from the other color channels, not by adding white, but producing specific white points along the black body curve.

Optics

The TrueSource optical systems are truly the next generation of optical design. The beams are flat, and fully collimated.

Each unit produces one shadow. A shadow that would be expected from a traditional source or natural sunlight. Of course diffusion can be added to soften or adjust the shadow, instead of starting from an unfamiliar shadow.

TrueSource at a Glance

- References international standards to describe color, CIE 1931 2° observer
- Uses multiple primary emitters to ensure full spectrum response
- Live color monitoring using Tristimulus sensor, sensing color similar to the human eye
- Wide gamut from one lighting instrument
- CRI above 95
- CCT Channel (as low as 1,800k up to 10,000k)
- Independent dimmer channel with no color shift
- A shadow that matches conventional sources
- 5 year warranty that includes color

Basic Installation

Before installing this product please make sure that you have read all warnings and safety information provided in this manual.

Caution: The product must be placed/mounted on a rack, shelf, or other suitable surface that is rated to support the weight of the product.

The product must also be placed such that the safety cable can be attached. The safety cable must be attached in such a way that it can not be removed without releasing the clip.

The safety cable should be attached at all times during both installation and removal of the product. Attaching the safety cable should be the first step before installing the product and the last step after removing the product.

Mounting the product

Step 1: Install a c-clamp or other appropriate rated pipe coupling device to the steel yoke of the RevEAL Studio Instrument.

Step 2: Loop the safety cable through your support, such that after clipping the carabiner the loop cannot slip off of your support.

Step 3: After ensuring that the loop cannot slip off of the support, clip the carabiner to the safety cable.

Step 4: Position the mouth of the c-clamp over your intended mounting surface. Once you are happy with the location, tighten the clamp until the product is secured to the surface.

Caution: The product should never be installed without the proper use of the safety cable. It is recommended that the side knobs may be tightened with a wrench on the flats inside of the handle.

Attaching Data and Power Cables

Note: This lighting fixture can be used individually or modules can be daisy chained. In a chain of fixtures each module can be individually addressed, or each can have its own address wherein each fixture is independent of the others.

Prism Projection Inc. - RevEAL Studio Operating Manual

Step 1: If Needed attach an appropriate connector to the end of the power cord included with the product. Any connector you attach to the end of the product must be rated for 15 Amperes and 250VAC, and of the grounding type. The conductors in the power cable are color coded for ease of assembly.

<u>Wire Color</u>	<u>Conductor function</u>
Green or Green with Yellow Stripe	GROUND
Blue or White	NEUTRAL
Brown or Black	LINE

Step 2: After attaching the appropriate connector to the power cord you can attach the power cord to the fixture. The power cord will go into the power-in port (blue). Slide the connector into the port and twist the connector clockwise.

Step 3: Now that the unit has power you need to provide data to the unit. This is done by plugging in an approved 5 pin DMX cable. The data-in port is found on the rear, of the fixture. If you have daisy chained your units, data-in from your second unit should come from the data-out port of the first unit. Continue attaching cables in this fashion, 1 to 2, 2 to 3, and so on. Follow best practices for DMX wiring, Do not exceed recommended cable lengths or number of receivers on a chain.

The unit may also be controlled via ArtNet. Contact Prism Projection for details.

Accessory Holder and Optional Hardware

Note: Due to the nature of the variable optical system used on the RevEAL Studio, at field angles less than 30°, there will appear several stray beams around the main field. Instead of permanently attaching mechanisms that would diminish output at all field angles, Prism encourages the use of either the Top Hat or Egg Crate accessory at beam angles below 30°

There are two slots for front mounted accessories on the RevEAL Studio. The forward most slot can take accessories up to 9.7 inches (232 mm) and has a rotation locking mechanism for circular doors or speed rings. The second slot has a dimension of 9.1" (232 mm), for gel frames containing diffusion or other accessories.

The slots are designed to accept many accessories commonly sized for "2K" fixtures.

The Safety clip on the top of the accessory holder area may be moved by squeezing the sides and pulling it towards the rear of the instrument.

Top Hat

Designed to reduce glare and catch "stray beams" at narrow field angles. May clip the edges of the beam at very wide angles.

Egg Crate

Reduces glare and catches "stray beams" at narrow angles. Not recommended for wide field short throw applications.

Wide Lenses

Also available are two holographic film lenses that mount into the accessory holder on the Front of the RevEAL Studio. A +20° lens will add 20° to the current field angle of the instrument, effectively making the spot to flood of 40° to 90°. The RT Lens will add 30° but only in one axis. This lens will create a soft rectangular shape. The RT is mounted in a circular housing so the rectangle created may be rotated. The field range of the instrument with an RT lens in place becomes: 20° x 50° to 70° x >90°

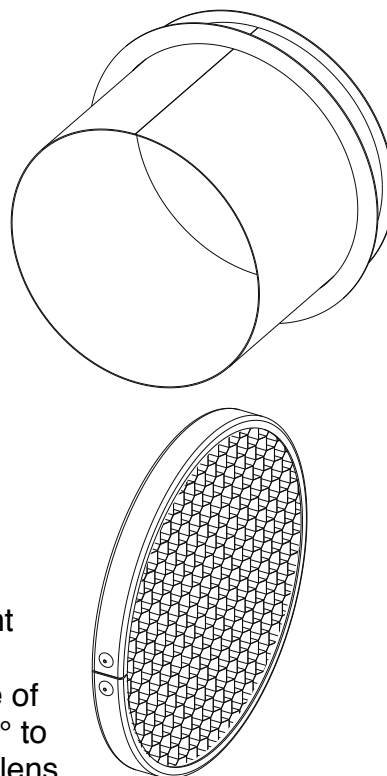

Interface Panel

Located on the rear of the instrument, all settings and options can be accessed by using the button pad and LCD on the Interface Panel.

From startup the LCD will be illuminated and cycle to the Home Screen. Pressing either the up or down keys will take the user to the other screens.

If the display is blacked out, pressing any button will illuminate the display's backlight.

The Home screen provides an at a glance view of the instrument's configuration and current settings. Including if the fan is spinning, theDMX start address, how many channels the configuration occupies, if DMX is being received, and the current values of each control parameter.

All settings can be accessed by using the up, down, left and right buttons. When a screen is highlighted use the check button to go to the highlighted section. Using the x button will always go back up one level. If a selection allows for multiple choices, left and right buttons will cycle through available options.

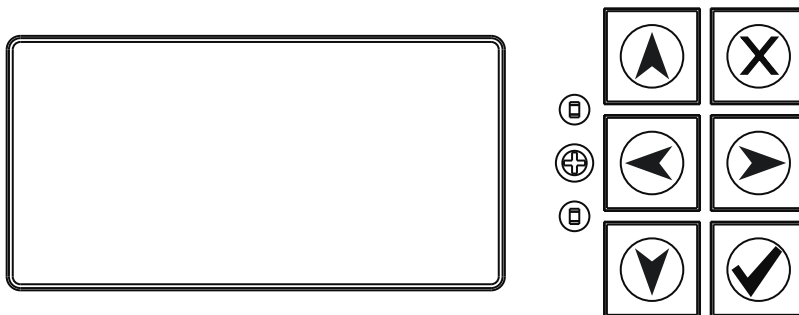

Menu Tree

Home Screen

Fixture Address

DMX Address (1 to 512)

Art-Net Universe (0-0 to 15-15)

Encoding (8-bit, 16-bit)

Channel Personality

Color (None, Cie XY, RGB, Hue+Sat, Dynamic)

White (Disabled, Enabled, Correction)

Intensity (Standard, Linear)

Advanced Settings

Energy (Full Power, Remote, Eco/Fanless)

Refresh Rate (Medium, High, Remote, Low)

Beam Angle (Local, Remote)

Algorithm (Brightness, Color)

Reset to Factory Defaults

Standalone Control

TrueSource

Demo Mode

Fixture Address

Step 1: Using the up and down arrows select either “DMX Address”, “Art-NetUniverse” or “Encoding”.

Step 2: Use the left and right arrow buttons to change the value of the selection.

DMX address may be 1-512, remember to leave enough room for the channels contained in the block as defined by the features enabled.

When setting Art-Net universes, hold down an arrow key until the sub net changes.

Modes and DMX Channels

RevEAL Instruments with TrueSource offer unparalleled options in how they are controlled. Ranging from simple one channel dimmed white light operation to obsessive control of almost every aspect of the fixture. There are over 1900 possible personalities, however determining which one is right for your show is straightforward and quick to set.

Operating modes are set by using the button pad to navigate to the Fixture Personality Menu. This menu allows the user to adjust; Color Mode, Color Temperature, Intensity (dimmer curve) and select Advanced Features.

If advanced features are not set to remote, the color channels will be the first channels available on the instrument.

Color Modes

Available Options: CIE xy, RGB, Hue + Sat, Dynamic, None

RevEAL instruments have 3 calibrated color modes, a dynamic color space mode and the option to only use white. Use the up and down buttons to select “**Color**” then use the left and right buttons to scroll through the available modes.

While RevEAL instruments contain 5 base colors of LEDs, they are controlled within calibrated color systems. This ensures that the TrueSource TriStimulus sensor can guarantee color match between instruments, over the life of the instrument.

Users may elect to use 16 bit control for color and intensity channels, from **Advanced Settings**. 16 bit control is only recommended for users with advanced lighting consoles.

CIE xy

CIE x,y allows the user to select color from the CIE 1931 2° Observer color space.

Many Gel Manufactures have available CIE coordinates measured in the 1964 10° Observer color space. These values will not generate the same colors as the 1931 2° Observer color space. 2° values may be obtained with a color sampling device.

To determine the DMX decimal values for a given coordinate, simply multiply the coordinate by 255. For example 3200K white light has an x value of 0.4254 and a y of 0.4044.

x value: $0.4254 \times 255 = 108$ (42%)
y value: $0.4044 \times 255 = 103$ (40%)

Prism Projection Inc. - RevEAL Studio Operating Manual

In 16 bit mode, the multiplier is 65535;

x value: $0.4254 \times 65535 = 27878$ (42%)

y value: $0.4044 \times 65535 = 26502$ (40%)

If the Color Temperature channel is enabled, the color temperature channel will “take over” color control from the color channels. Generating white light in the Kelvin value specified by the Color Temperature channel. To transition from a specific color temperature to a specific color, use the x,y values for color temperatures found in the Appendix.

CIE x,y DMX Map (8 bit control):

1st Color Channel	2nd Color Channel
x coordinate	y coordinate

CIE x,y DMX Map (16 bit control):

1st Color Channel	2nd Color Channel	3rd Color Channel	4th Color Channel
x course	x fine	y course	y fine

RGB

RGB mode allows for familiar Red, Green and Blue control channels. With all channels full, white light will be produced. Unless changed in advanced settings or the color temperature channel is set to remote, the default white point is 3200K. With all channels at 0 no light will be produced regardless of the intensity channel's state.

To translate from CMY values a general rule of thumb is to invert the values. ie:

Cyan = Red @ 0, Green @ Full, Blue @ Full

Magenta = Red @ Full, Green @ 0, Blue @ Full

Yellow = Red @ Full, Green @ Full, Blue @ 0

While not completely accurate, because of subtractive filter technology, this will help get RevEAL instruments to a color near CMY based fixtures.

RGB DMX Map (8 bit control):

1st Color Channel	2nd Color Channel	3rd Color Channel
Red	Green	Blue

RGB DMX Map (16 bit control):

1st Channel	2nd Channel	3rd Channel	4th Channel	5th Channel	6th Channel
Red Course	Red Fine	Green Course	Green Fine	Blue Course	Blue Fine

Hue + Sat

Hue + Saturation mode is easiest to think of as common color pickers on photo editing software, commonly abbreviated to HSI or HSL. The Hue channel defines an angle on

Prism Projection Inc. - RevEAL Studio Operating Manual

the color wheel, and saturation defines how far from white (the center) of the wheel the color is. Red is at 0° (DMX @ 0) and 360° (DMX @ Full). Green is at 120°, Blue at 240°. The Saturation channel, moves the color closer to the center, creating white. The white point is set either in advanced settings or controlled remotely by the Color Temperature channel, the default is 3200k.

Hue + Sat DMX Map (8 bit control):

1st Color Channel	2nd Color Channel
Hue Angle	Saturation

Hue + Sat DMX Map (16 bit control):

1st Color Channel	2nd Color Channel	3rd Color Channel	4th Color Channel
Hue Course	Hue Fine	Sat Course	Sat Fine

Dynamic

Dynamic Color mode allows remote DMX control of which color mode the instrument is in. Dynamic mode will add one channel at the beginning of the color block. the position of this channel determines the color mode used. Because not all color modes use the same number of channels, in Dynamic there may be empty channels.

The Dynamic color channel is broken up into 5 zones. DMX 0-51(20%) sets the color channels into CIE x,y. DMX 102(40%)-153(60%) set the color channels into RBG. DMX 204(80%)-Full sets the color channels into Hue + Sat.

Dynamic DMX Map (8 bit control):

1st Color Channel	2nd Color Channel	3rd Color Channel	4th Color Channel
Control @ 0	x	y	empty
Control @ 50%	Red	Green	Blue
Control @ Full	Hue	Sat	empty

Dynamic DMX Map (16 bit control):

1st Channel	2nd Channel	3rd Channel	4th Channel	5th Channel	6th Channel	7th Channel
Control @ 0	x course	x fine	y course	y fine	empty	empty
@ 50%	Red course	Red Fine	Green Course	Green Fine	Blue Course	Blue Fine
@ Full	Hue Course	Hue Fine	Sat Course	Sat Fine	empty	empty

None

If None mode is selected, the instrument will not include color channels. In its simplest settings, this mode may be used to only have a CCT and intensity channel on the instrument. RevEAL fixtures do not shift color while dimming. If you are attempting to match white with tungsten based lamps that are dimmed, make sure to enable remote control of Color Temperature.

White (CCT)

Available Options: Enabled, Disabled, Correction

When enabled the White setting creates a Correlated Color Temperature (CCT) Channel. If the CCT channel is at any value other than 0, white colors will be produced by the instrument. At full the color generated will be 8000K white, at 11% the color generated will be ~3200K white. As the channel value is raised the color temperature will go up.

If CCT is at any value other than 0 and the Color Mode is any setting other than None, the instrument will ignore the color channels and only create white light. Moving the CCT channel to 0 will bump the instrument to wherever the color channels are set.

If the Correction option is selected, a channel will be added following the CCT channel that allows for the adjustment of green and magenta in the CCT output. **The Correction channel should be defaulted to 50% (127) for no correction.** Raising the Correction channel will add up to 5 units of green. While lowering the Correction channel will add up to 5 units of magenta. This feature is important of the user is attempting to balance to sources that may have color shift towards green or magenta, such as fluorescents or only white LED devices.

If using the Correction option, ensure that Color is selected for the Algorithm found in Advanced Settings.

If enabled, in 8 bit mode 1 channel will be added after the color channels, 2 channels will be added if 16 bit control is being used.

If Correction is selected, in 8 bit mode 2 channels will be added after the color channels, 4 channels will be added if 16 bit control is being used. CCT channel(s) then Correction channel(s).

Intensity

Available Options: Linear, Standard

Users may select either from a linear dimming curve or square law dimming. Square law dimming is frequently used in television production with the low end and top end of the dimming curve are smoothed out.

RevEAL instruments always use an intensity channel, in 16 bit operation 2 channels are used.

Advanced Settings

Advanced Settings are available in the Channel Personality screen.

Energy

Available Options: Full Power, Remote, ECO / Fanless

Full Power

With Full Power Selected the instrument will use all active cooling including the fan and produce the brightest possible output.

Remote

If Remote is selected a control channel will added at the beginning of the DMX address block. At full this channel will turn off the fan, output of the instrument will be diminished. The amount that output will be diminished is dependent on the color being produced. In general it is between 40-50%. A value other than full will put the fixture in full power mode.

ECO / Fanless

ECO mode turns off the fan, the instrument will operate virtually silently, with diminished output. ECO mode will run the instrument with incredibly high efficiency. The total wattage draw of the instrument will be significantly reduced depending on color. The output of the fixture will also be reduced.

Beam Angle

Available Options: Local, Remote

Local

Beam Angle set to Local will turn off the control channel that operates the automated lens zoom system. Beam angle may be adjusted by using the potentiometer knob located on the top of the rear panel.

Remote

Beam Angle set to Remote enables a control channel to adjust the beam angle of the instrument. At 0 the beam angle will be the widest setting of $\sim 70^\circ$. At Full the beam angle will be at its narrowest setting of $\sim 20^\circ$. The beam potentiometer on the rear of the fixture will still control the beam angle in a latest takes precedence (LTP) style operation. If the local control knob is used the instrument will go to that position until DMX on the remote channel is changed.

Prism Projection Inc. - RevEAL Studio Operating Manual

The Beam Angle Control channel is not linear. See below for a guide to DMX value and beam angle:

DMX Value	DMX %	Field Angle
0	0%	~70°
51	20%	~60°
76	30%	~50°
102	40%	~40°
127	50%	~30°
178	75%	~25°
255	100%	~20°

Algorithm

Available Options: Brightness, Color

Brightness

Brightness algorithm will force the fixture to generate the brightest possible output. When changing color the user may notice slight jumps in brightness.

Color

The color algorithm smoothes transitions between colors, and allows for some improved subtlety of color.

Color algorithm should be used when the Correction option in the White setting is selected.

Reset to Factory Defaults

Setting to factory defaults will put the fixture at address 1 with the following channel assignments:

- 1) x
- 2) y
- 3) CCT
- 4) Dimmer

Channel Map

The DMX channel map will change based on user selected settings. There are four potential blocks of channels.

Advanced Settings | Color Mode | White | Dimmer

The first is for advanced settings, ECO in channel 1, Beam Angle in Channel 2. If either options are at a setting that does not use DMX channels, the channel slot will not be occupied.

The color block may contain no channels or up to 7 if dynamic mode in 16 bit is enabled.

The white block may contain no channels or 2 if 16 bit is enabled. One channel is used in 8 bit mode.

The dimmer channel block is always present.

For example a common set up is: Beam = Remote, Color = Dynamic, White = Remote operating in 8 bit. Below is the channel block for the fixture:

- 1) Beam
- 2) Color Mode Selector
- 3) x, R, Hue
- 4) y, G, Saturation
- 5) unused, B, unused
- 6) CCT
- 7) Dimmer

Standalone Control

Navigating to Standalone Control allows the user to create light without DMX present. To ensure there is no change in the light being produced it is recommended that DMX cables be removed while using standalone control.

Use the up and down arrows to select the parameter to change, then use the left right arrows to change the parameter.

Pressing the X button will return to the previous screen.

To ensure that the light settings established in the Standalone Control mode are maintained through power cycles, always power off the unit from the Standalone Control screen display.

TrueSource Screen

The TrueSource screen allows the user to verify that the TrueSource system is functioning properly. Target and Measured x,y values are shown.

A demo loop may also be triggered from this screen.